

ZADATAK 2.

KONTINUIRANI NOSAČ

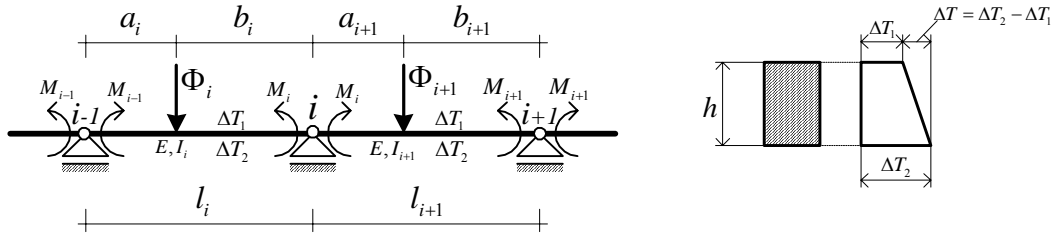

Uvjet deformacija: $\varphi_i^{\text{lijevo}} = \varphi_i^{\text{desno}} \Rightarrow$ Jednadžba triju momenata ili **Clapeyronova jednadžba**:

$$M_{i-1} \cdot \frac{l_i}{I_i} + 2 \cdot M_i \cdot \left(\frac{l_i}{I_i} + \frac{l_{i+1}}{I_{i+1}} \right) + M_{i+1} \cdot \frac{l_{i+1}}{I_{i+1}} = -6 \cdot \left(\frac{\Phi_i \cdot a_i}{I_i \cdot l_i} + \frac{\Phi_{i+1} \cdot b_{i+1}}{I_{i+1} \cdot l_{i+1}} \right) - 3 \cdot E \cdot \alpha_T \cdot \Delta T \cdot \left(\frac{l_i}{h_i} + \frac{l_{i+1}}{h_{i+1}} \right)$$

$$I = \text{const}$$

$$h = \text{const}$$

$$\Delta T = \Delta T_2 - \Delta T_1$$

$$M_{i-1} \cdot l_i + 2 \cdot M_i \cdot (l_i + l_{i+1}) + M_{i+1} \cdot l_{i+1} = -6 \cdot \left(\Phi_i \cdot \frac{a_i}{l_i} + \Phi_{i+1} \cdot \frac{b_{i+1}}{l_{i+1}} \right) - 3 \cdot E \cdot I \cdot \alpha_T \cdot \frac{\Delta T}{h} \cdot (l_i + l_{i+1})$$

ZADATAK

Za kontinuirani nosač prikazan na slici treba odrediti dijagrame unutarnjih sila.

Nosač je opterećen silama F , a u polju **1-2** se temperatura gornjih vlakana promjenila za $\Delta T_1 = 40 \text{ K}$, a donjih za $\Delta T_2 = 20 \text{ K}$. Po visini poprečnog presjeka temperatura se mijenja po linearnom zakonu.

$$\text{Zadano je: } E = 2,0 \cdot 10^5 \text{ MPa} \quad h = 300 \text{ mm}$$

$$I = 1,2 \cdot 10^8 \text{ mm}^4 \quad F = 90 \text{ kN}$$

$$\alpha_T = 1,4 \cdot 10^{-4} / \text{K}$$

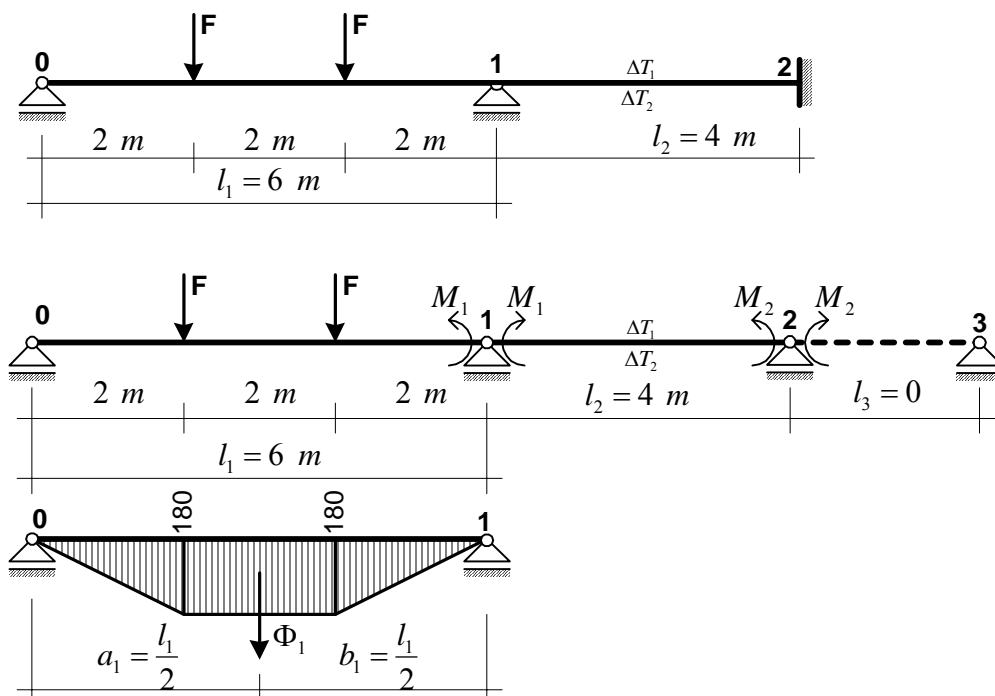

LEŽAJ 1

$$M_0 \cdot l_1 + 2 \cdot M_1 \cdot (l_1 + l_2) + M_2 \cdot l_2 = -6 \cdot \left(\Phi_1 \cdot \frac{a_1}{l_1} + \Phi_2 \cdot \frac{b_2}{l_2} \right) - 3 \cdot E \cdot I \cdot \alpha_T \cdot \frac{\Delta T}{h} \cdot l_2$$

LEŽAJ 2

$$M_1 \cdot l_2 + 2 \cdot M_2 \cdot (l_2 + l_3) + M_3 \cdot l_3 = -6 \cdot (0 + 0) - 3 \cdot E \cdot I \cdot \alpha_T \cdot \frac{\Delta T}{h} \cdot l_2$$

$$M_0 = 0, \quad l_3 = 0, \quad \Phi_2 = 0$$

$$\Delta T = \Delta T_2 - \Delta T_1 = 20 - 40 = -20 \text{ K}$$

$$\Phi_1 = \frac{180 \cdot 2}{2} \cdot 2 + 180 \cdot 2 = 720 \text{ kNm}^2 \quad a_1 = \frac{l_1}{2}$$

$$\Phi_1 \cdot \frac{a_1}{l_1} = 720 \cdot \frac{1}{2} = 360 \text{ kNm}^2$$

LEŽAJ 1

$$2 \cdot M_1 \cdot (6 + 4) + M_2 \cdot 4 = -6 \cdot 360 - 3 \cdot 2 \cdot 10^5 \cdot 1,2 \cdot 10^8 \cdot 10^{-9} \cdot 1,4 \cdot 10^{-4} \cdot \frac{(-20)}{0,3} \cdot 4$$

$$20 \cdot M_1 + 4 \cdot M_2 = 528 \text{ kNm}^2$$

LEŽAJ 2

$$M_1 \cdot 4 + 2 \cdot M_2 \cdot 4 = -3 \cdot 2 \cdot 10^5 \cdot 1,2 \cdot 10^8 \cdot 10^{-9} \cdot 1,4 \cdot 10^{-4} \cdot \frac{(-20)}{0,3} \cdot 4$$

$$4 \cdot M_1 + 8 \cdot M_2 = 2688 \text{ kNm}^2$$

$$20 \cdot M_1 + 4 \cdot M_2 = 528 \text{ kNm}^2$$

$$4 \cdot M_1 + 8 \cdot M_2 = 2688 \text{ kNm}^2 \quad \Rightarrow \quad \underline{M_1 = -45,33 \text{ kNm}} \quad \underline{M_2 = +358,67 \text{ kNm}}$$

ODREĐIVANJE REAKCIJA

Raspon l_1

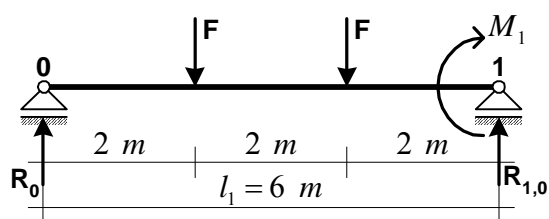

$$\Sigma M_0 = 0$$

$$R_{1,0} \cdot 6,0 - M_1 - F \cdot 2,0 - F \cdot 4,0 = 0$$

$$R_{0,1} = +97,56 \text{ kN}$$

$$\Sigma M_1 = 0$$

$$R_0 \cdot 6,0 + M_1 - F \cdot 2,0 - F \cdot 4,0 = 0$$

$$R_0 = +82,45 \text{ kN}$$

Raspon l_2

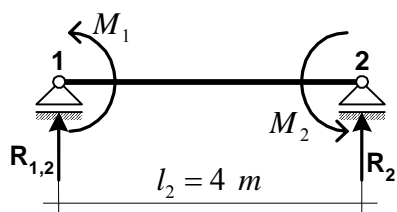

$$\Sigma M_1 = 0$$

$$R_2 \cdot 4,0 + M_2 + M_1 = 0$$

$$R_2 = -101,0 \text{ kN}$$

$$\Sigma M_2 = 0$$

$$R_{1,2} \cdot 4,0 - M_2 - M_1 = 0$$

$$R_{1,2} = +101,0 \text{ kN} = -R_2$$

DIJAGRAMI UNUTARNJIH SILA

$$R_1 = R_{1,0} + R_{1,2} = 198,56 \text{ kN}$$

$$M_A = R_0 \cdot 2 = +164,90 \text{ kNm}$$

$$M_B = R_0 \cdot 4 - F \cdot 2 = +149,8 \text{ kNm}$$

