

## NOSAČ NA ELASTIČNOJ PODLOZI

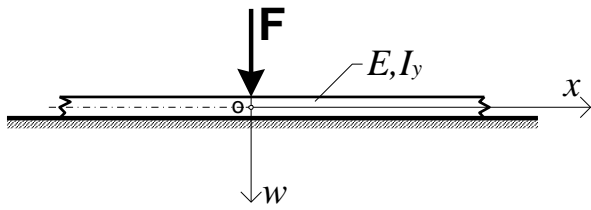

$$w = \frac{F}{8 \cdot E \cdot I_y \cdot \alpha^3} \cdot e^{-\alpha x} \cdot [\cos(\alpha x) + \sin(\alpha x)] \quad x \geq 0$$

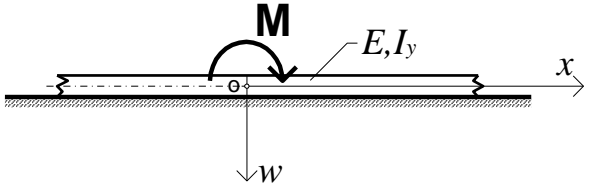

$$w = \frac{M}{4 \cdot E \cdot I_y \cdot \alpha^2} \cdot e^{-\alpha x} \cdot \sin(\alpha x) \quad x \geq 0$$

Modul podloge:  $k_1 [MN/m^3]$

Koeficijent podloge:  $k = k_1 \cdot b [Pa]$

Širina nosača:  $b [m]$

Parametar  $\alpha$  koji ovisi o odnosu krutosti nosača i elastične podloge:  $\alpha = \sqrt[4]{\frac{k}{4 \cdot E \cdot I_y}}$

### ZADATAK 3.

Treba odrediti smjer i veličinu glavnih naprezanja u točki "C" presjeka 1-1 beskonačno dugog nosača na elastičnoj podlozi opterećenog prema slici.

Zadan je modul elastičnosti nosača  $E = 2,0 \cdot 10^5 \text{ MPa}$  i modul podloge  $k_1 = 8000 \text{ MN/m}^3 = 8 \text{ N/mm}^3$ .

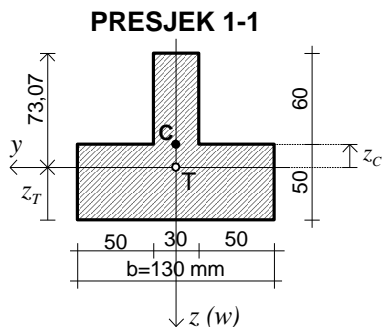
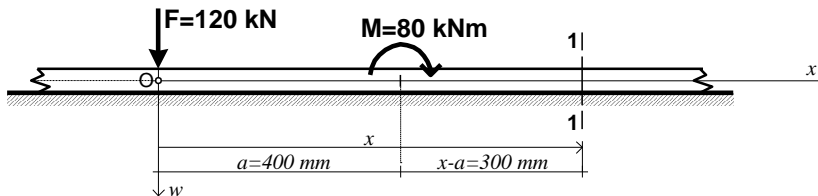

$$A = 8300 \text{ mm}^2$$

$$z_T = 36,93 \text{ mm}$$

$$I_y = 6,16 \cdot 10^6 \text{ mm}^4$$

$$z_C = -13,07 \text{ mm}$$

$$S_y^C = 30 \cdot 60 \cdot (73,07 - 30) = 77562 \text{ mm}^3$$

Koeficijent podloge:  $k = k_1 \cdot b = 8000 \cdot 0,13 = 1040 \text{ MN/m}^2 = 1040 \text{ MPa} \text{ (N/mm}^2\text{)}$

Parametar  $\alpha$  koji ovisi o odnosu krutosti nosača i elastične podloge:

$$\alpha = \sqrt[4]{\frac{k}{4 \cdot E \cdot I_y}} = \sqrt[4]{\frac{1040}{4 \cdot 2,0 \cdot 10^5 \cdot 6,16 \cdot 10^6}} = 3,811 \cdot 10^{-3} \frac{1}{\text{mm}}$$

Jednadžba elastične linije nosača:

$$w = \frac{F}{8 \cdot E \cdot I_y \cdot \alpha^3} \cdot e^{-\alpha x} \cdot [\cos(\alpha x) + \sin(\alpha x)] + \frac{M}{4 \cdot E \cdot I_y \cdot \alpha^2} \cdot e^{-\alpha(x-a)} \cdot \sin[\alpha(x-a)]$$

Jednadžba za kutove zaokreta:

$$w' = \varphi = -\frac{F}{4 \cdot E \cdot I_y \cdot \alpha^2} \cdot e^{-\alpha x} \cdot \sin(\alpha x) + \frac{M}{4 \cdot E \cdot I_y \cdot \alpha} \cdot e^{-\alpha(x-a)} \cdot \{\cos[\alpha(x-a)] - \sin[\alpha(x-a)]\}$$

Jednadžba za momente savijanja:

$$w'' = -\frac{F}{4 \cdot E \cdot I_y \cdot \alpha} \cdot e^{-\alpha x} \cdot [\cos(\alpha x) - \sin(\alpha x)] - \frac{M}{2 \cdot E \cdot I_y} \cdot e^{-\alpha(x-a)} \cdot \cos[\alpha(x-a)] = -\frac{M(x)}{E \cdot I_y}$$

Jednadžba za poprečne sile:

$$w''' = \frac{F}{2 \cdot E \cdot I_y} \cdot e^{-\alpha x} \cdot \cos(\alpha x) + \frac{M \cdot \alpha}{2 \cdot E \cdot I_y} \cdot e^{-\alpha(x-a)} \cdot \{\cos[\alpha(x-a)] + \sin[\alpha(x-a)]\} = -\frac{T(x)}{E \cdot I_y}$$

Izraz za momente savijanja:

$$M(x) = +\frac{F}{4 \cdot \alpha} \cdot e^{-\alpha x} \cdot [\cos(\alpha x) - \sin(\alpha x)] + \frac{M}{2} \cdot e^{-\alpha(x-a)} \cdot \cos[\alpha(x-a)]$$

Izraz za poprečne sile:

$$T(x) = -\frac{F}{2} \cdot e^{-\alpha x} \cdot \cos(\alpha x) - \frac{M \cdot \alpha}{2} \cdot e^{-\alpha(x-a)} \cdot \{\cos[\alpha(x-a)] + \sin[\alpha(x-a)]\}$$

Za  $x = 700 \text{ mm}$ :

$\alpha \cdot x = 2,677$	$\sin(\alpha x) = 0,45635$	$\cos(\alpha x) = -0,8898$
$\alpha \cdot (x - a) = 1,1433$	$\sin[\alpha(x - a)] = 0,9100$	$\cos[\alpha(x - a)] = 0,4146$
$e^{-\alpha x} = 0,06941$		
$e^{-\alpha(x-a)} = 0,3188$		

Moment savijanja i poprečna sila u presjeku 1-1 ( $x = 700 \text{ mm}$ ):

$$M_{1-1} = +\frac{F}{4 \cdot \alpha} \cdot e^{-\alpha x} \cdot [\cos(\alpha x) - \sin(\alpha x)] + \frac{M}{2} \cdot e^{-\alpha(x-a)} \cdot \cos[\alpha(x-a)] = +4,55 \text{ kNm}$$

$$T_{1-1} = -\frac{F}{2} \cdot e^{-\alpha x} \cdot \cos(\alpha x) - \frac{M \cdot \alpha}{2} \cdot e^{-\alpha(x-a)} \cdot \{\cos[\alpha(x-a)] + \sin[\alpha(x-a)]\} = -60,67 \text{ kN}$$

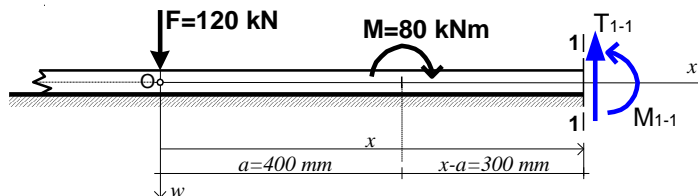

Normalno naprezanje u točki C:  $\sigma_x^C = \frac{M_{1-1}}{I_y} \cdot z_C = -9,65 \text{ MPa}$  (tlak)

Posmično naprezanje u točki C:  $\tau_{xz}^C = \frac{T_{1-1} \cdot S_y^C}{I_y \cdot b_C} = -25,45 \text{ MPa}$

Veličina glavnih naprezanja: 
$$\sigma_{1,2}^C = \frac{\sigma_x^C}{2} \pm \frac{1}{2} \cdot \sqrt{(\sigma_x^C)^2 + 4 \cdot (\tau_{xz}^C)^2} = -4,825 \pm 25,903 \text{ (MPa)}$$

$$\sigma_1^C = +21,08 \text{ MPa}$$

$$\sigma_2^C = -30,73 \text{ MPa}$$

Kontrola:  $\sigma_1^C + \sigma_2^C = \sigma_x^C + \sigma_y^C \quad (\sigma_y^C = 0)$

Smjer glavnih naprezanja: 
$$\operatorname{tg}(2\varphi_o) = \frac{2 \cdot \tau_{xz}^C}{\sigma_x^C} = +5,2746 \quad \Rightarrow \quad \varphi_o = +39,63^\circ$$

$$\operatorname{tg}\varphi_{o1} = \frac{\tau_{xz}^C}{\sigma_2^C - \sigma_y^C} = -1,2073 \quad \Rightarrow \quad \varphi_{o1} = -50,36^\circ$$

$$\operatorname{tg}\varphi_{o2} = \frac{\tau_{xz}^C}{\sigma_2^C - \sigma_y^C} = +0,8282 \quad \Rightarrow \quad \varphi_{o2} = +39,63^\circ$$

Kontrola:  $|\varphi_{o1}| + |\varphi_{o2}| = 90^\circ$

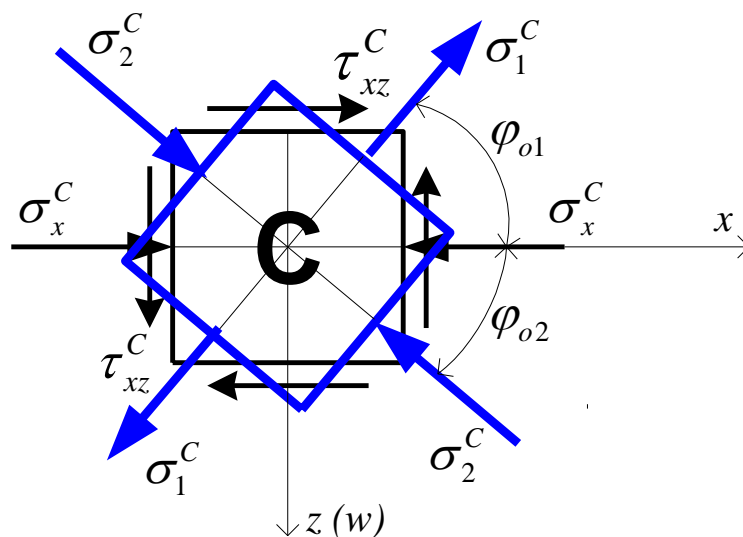

U nastavku su još **4 primjera** izraza za progib u presjeku I-I, ovisno o položaju presjeka u odnosu na opterećenje nosača na elastičnoj podlozi (1. primjer je isti kao u prethodnom zadatku).

Kut zaokreta, moment savijanja i poprečnu silu u presjeku dobijemo nakon prve, druge i treće derivacija izraza za progib.

Kut zaokreta u presjeku I-I:  $\varphi_{I-I} = w'(x)$

Moment savijanja u presjeku I-I:  $M_{I-I} = -E \cdot I_y \cdot w''(x)$

Poprečna sila u presjeku I-I:  $T_{I-I} = -E \cdot I_y \cdot w'''(x)$

1. primjer

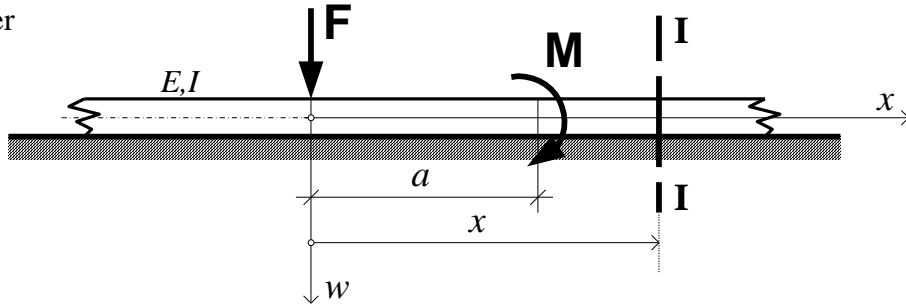

$$w = \frac{F}{8EI\alpha^3} \cdot e^{-\alpha x} (\sin \alpha x + \cos \alpha x) + \frac{M}{4EI\alpha^2} \cdot e^{-\alpha(x-a)} \sin \alpha(x-a)$$

2. primjer

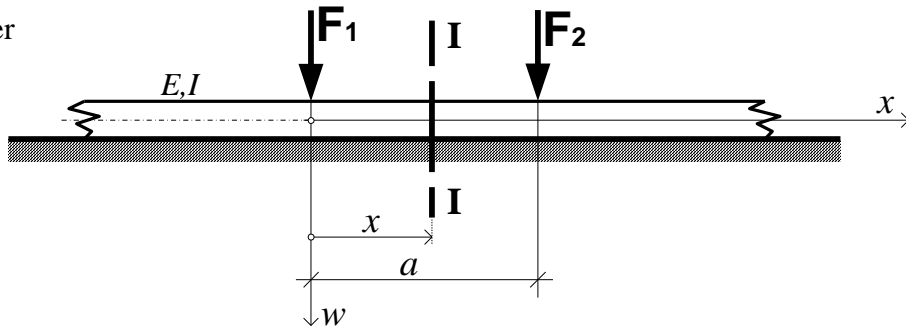

$$w = \frac{F_1}{8EI\alpha^3} \cdot e^{-\alpha x} (\sin \alpha x + \cos \alpha x) + \frac{F_2}{8EI\alpha^3} \cdot e^{-\alpha(a-x)} [\sin \alpha(a-x) + \cos \alpha(a-x)]$$

3. primjer

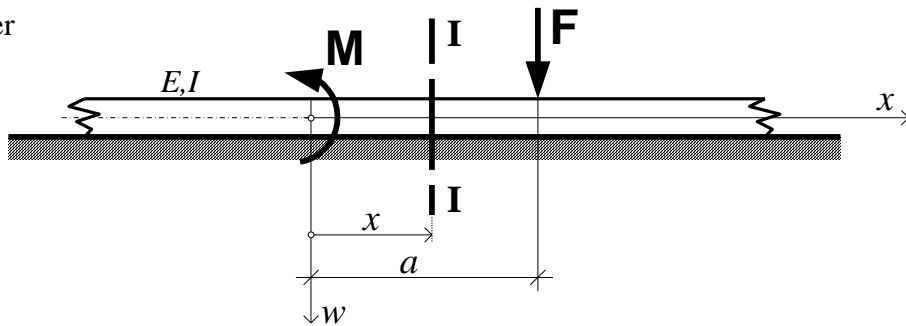

$$w = -\frac{M}{4EI\alpha^2} \cdot e^{-\alpha x} \sin \alpha x + \frac{F}{8EI\alpha^3} \cdot e^{-\alpha(a-x)} [\cos \alpha(a-x) + \sin \alpha(a-x)]$$

4. primjer

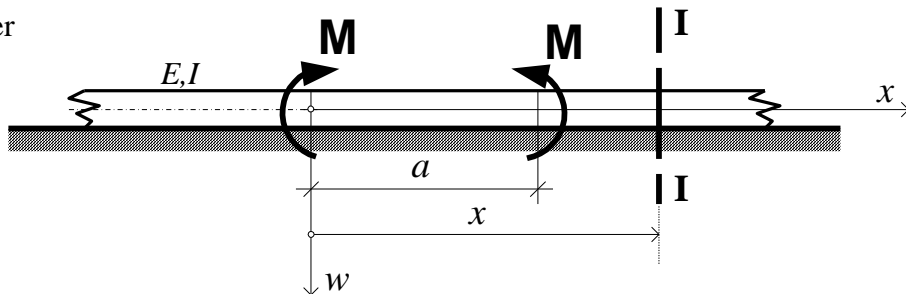

$$w = \frac{M}{4EI\alpha^2} \cdot e^{-\alpha x} \sin \alpha x - \frac{M}{4EI\alpha^2} \cdot e^{-\alpha(x-a)} \sin \alpha(x-a)$$